

SEACOMAIR CNG 150 SILENT

High pressure Compressed Natural Gas Compressor



CNG refilling system Designed for natural gas at a middle rate to 170 l/min (6 cfm).

Standard Features

- Durable powder coated, compact sound absorbing cabinet for stationary operation
- **Flame proof Sound isolation**
- **Remote MEPC Main Electric Control Panel**
- **On/Off Switch, Emergency OFF switch, Hour meter**
- Suction valve to connect Natural Gas
- **Antistatic Drive Belt**
- Manual condensate drain
- **Interstage Safety Pressure switch on 1st stage**
- Oil level sight glass indicator
- **Final recharge pressure gauge**
- Pressure maintaining valve
- Purification Cartridge Holder with purification system activated carbon/molecular sieve
- **ATEX Explosion proof AC motor 4 kW 230/400/440V, 3 Phase, available in 50 Hz or 60 Hz**
- **Filling hose 4,5 meters with CNG filling nozzle NGV1**
- Refill Time: 80 Liter (560 cu.ft.) cylinder in 1,5 hours from 0-3000 psi/0-200 bar
- One year warranty
- Noise level: 95 dB (ISO3746)
- Weight: 396 lbs (180 Kg)
- Dimensions: L 27,5" (70) x D 26" (67) x H 41" (105 cm)

Specifications

- Construction: Compressed Natural Gas compressor, Continuous duty air cooled, three stage, three cylinder CNG compressor, stainless steel interstage and final stage coolers
Cooling fan with antistatic blades and belt
Mounted in a powder coated steel cabinet
Sound absorbing housing
- Input pressure: 30 mbar
Max Pressure: 220bar/3190psi
Approx. Output: 170 l/min / 6 cfm / 10 m³/h
Max R.P.M.: 1300
Oil Type: SeaComAir synthetic compressor oil ISO CE
Oil Capacity: 1,7 Liters (59 oz.)
Drive motor: AC el. motor 230/400/440 Volt, 50-60 Hz 3 phase
- Features:
Manual condensate drain system
Final pressure gauge and emergency shut-off
Final Pressure gauge
On/Off Switch
Compressor ATEX 94/9/EC, PED 97/23/EC approved

Factory Options

- BAC5002: Filling hose Brake Away Safety Controll

Type

Model	Description	Charging Rate	Drive Motor
SCA150E43/CNG-SL	CNG HP-Compressor 220 bar	170 l/min/6 cfm/10 m ³ /h	4kW 230/400/440V/50Hz 3 Phase



www.seacomair.com

SeaComAir
Grenzhub 5a • 83229 Aschau • Germany
Tel. +49/(0)8057/904674
e-mail: info@seacomair.com

Price and Specification are subject to change without notice. All pricing EX-Works.

SEACOMAIR CNG 150 SILENT

Charging rate 170 l/min. (6 cfm)

Compact size for small Industry applications!

SCA150E43/CNG open



SCA150E43/CNG open

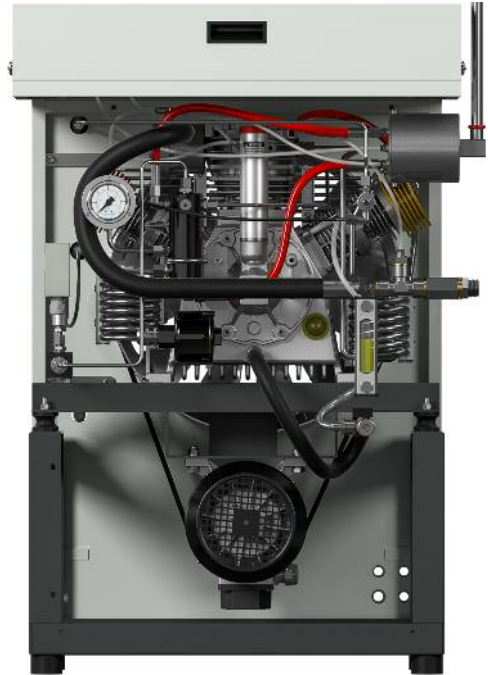

SCA150-MECP Main Electric Control Panel



SCA150 Purification Filter System with filter



MECP Standard Features

- Control Panel not ATEX approved, must be stationed outside of compressor
- Powder coated compact cabinet
- Hourmeter analog
- Main Control On/Off switch
- Electric Motor wrong rotation light
- Tension
- Hourmeter analog
- Emergency Off switch

Standard Features

- High pressure purification filter with filter housing
- One repackable filter with molecular sieve



www.seacomair.com

SeaComAir

Grenzhub 5a • 83229 Aschau • Germany

Tel. +49/(0)8057/904674

e-mail: info@seacomair.com

Price and Specification are subject to change without notice. All pricing EX-Works.

SEACOMAIR CNG 400 SILENT

*High pressure Compressed Natural Gas
Compressor Silent fully automatic*



Meets all international
Natural Gas standards
ATEX 2014/34/EU
PED 2014/68/EU
Machine 2006/42/EG

ISO9001: 2009
Certified Factory



*The most user-friendly CNG refilling system
available today. Designed for high natural gas
demand at a fast rate to 400 l/min (14 cfm).*

Standard Features

- Durable powder coated, compact sound absorbing cabinet for stationary operation
- **Remote MEPC Main Electric Control Panel**
- **On/Off Switch, Emergency OFF switch, Hour meter**
- **Gas temperature, Oil level warning light**
- Suction valve to connect Natural gas
- Intake Filter placed outside, easy to replace
- Manual condensate drain
- **Interstage Safety Pressure switch on 1st, 2nd and 3rd stage**
- **Low oil warning light**
- Oil level sight glass indicator
- **Oil pressure gauge**
- **Final recharge pressure gauge**
- Pressure maintaining valve
- Two Purification Cartridge Holders inside housing with purification system activated carbon and molecular sieve
- **Explosion proof AC motor 9kW 230/400/440 volt, 3 phase, available in 50 Hz or 60 Hz**
- **Filling hose 4,5 meters with CNG filling nozzle NGV1**
- Refill Time: 80 Liter (560 cu.ft.) cylinder in app. 40 min. from 0-3000 psi/0-200 bar
- One year warranty
- Noise level 87 dB (ISO3746)
- Weight: 925 lbs (420 Kg)
- Dimensions: L 32" (82) x D 52" (133) x H 70" (179 cm)

Specifications

Construction: Compressed Natural Gas compressor, Continuous duty air cooled, four stage, four cylinder CNG compressor, all stainless steel interstage and final stage coolers
Cooling fan with antistatic blades and belt
Mounted in a powder coated steel cabinet
Sound absorbing housing

Max Pressure: 250bar/3800psi
Approx. Output: 400 l/min / 14 cfm / 24 m³/h
Max R.P.M.: 1250
Lubrication: Low pressure oil injection pump
Oil Type: SeaComAir synthetic compressor oil ISO CE
Oil Capacity: 4,5 Liters (157 oz.)
Drive motor: AC electric motor 230/400/440 Volt, 3 phase 50Hz o.60Hz

Features: Manual condensate drain system
Final pressure gauge and emergency shut-off,
Low oil warning light
Gas temperature,
On/Off Switch,
ATEX 2014/34/EU, PED 2014/68/EU,
Machine 2006/42/EG approved

Factory Options

- BAC5002: Filling hose Brake Away Safety Control

Type

Model	Description	Charging Rate	Drive Motor
SCA400E43/CNG-SL	CNG HP-Compressor 250 bar	400 l/min/14 cfm/24 m ³ /h	9kW Electric 230/400/440V/50Hz o. 60Hz. 3Ph



www.seacomair.com

SeaComAir
Grenzhub 5a • 83229 Aschau • Germany
Tel. +49/(0)8057/904674
e-mail: info@seacomair.com

Price and Specification are subject to change without notice. All pricing EX-Works.

SEACOMAIR CNG 400 SILENT

*Charging rate 400 l/min. (14 cfm)
Compact size for Industrial applications!*

SCA400E43/CNG open



SCA400E43/CNG Filter housings



SCA400-MECP Main Electric Control Panel



SCA400-PFS Purification Filter System with filters



MECP Standard Features

- Control Panel not ATEX approved, must be stationed outside of compressor cabinet
- Hourmeter analog
- Main Control On/Off switch
- Gas temperature digital control
- AC Power light
- Electric Motor fault light indicator
- Electric Motor wrong rotation light
- Low oil status light
- Gas temperature fault light indicator
- 1st Stage pressure alarm light indicator
- 2nd Stage pressure alarm light indicator
- 3rd Stage pressure alarm light indicator
- Ready light to start
- AC El.Motor Power switch On
- Emergency Off switch

PFS Standard Features

- High pressure purification filter system with two filter housings
- Molecular Sieve filter



www.seacomair.com

SeaComAir
Grenzhub 5a • 83229 Aschau • Germany
Tel. +49/(0)8057/904674
e-mail: info@seacomair.com

Price and Specification are subject to change without notice. All pricing EX-Works.